

REV	DATE	REV. BY	CHKD. BY	DESCRIPTION OF REVISION	REMARKS

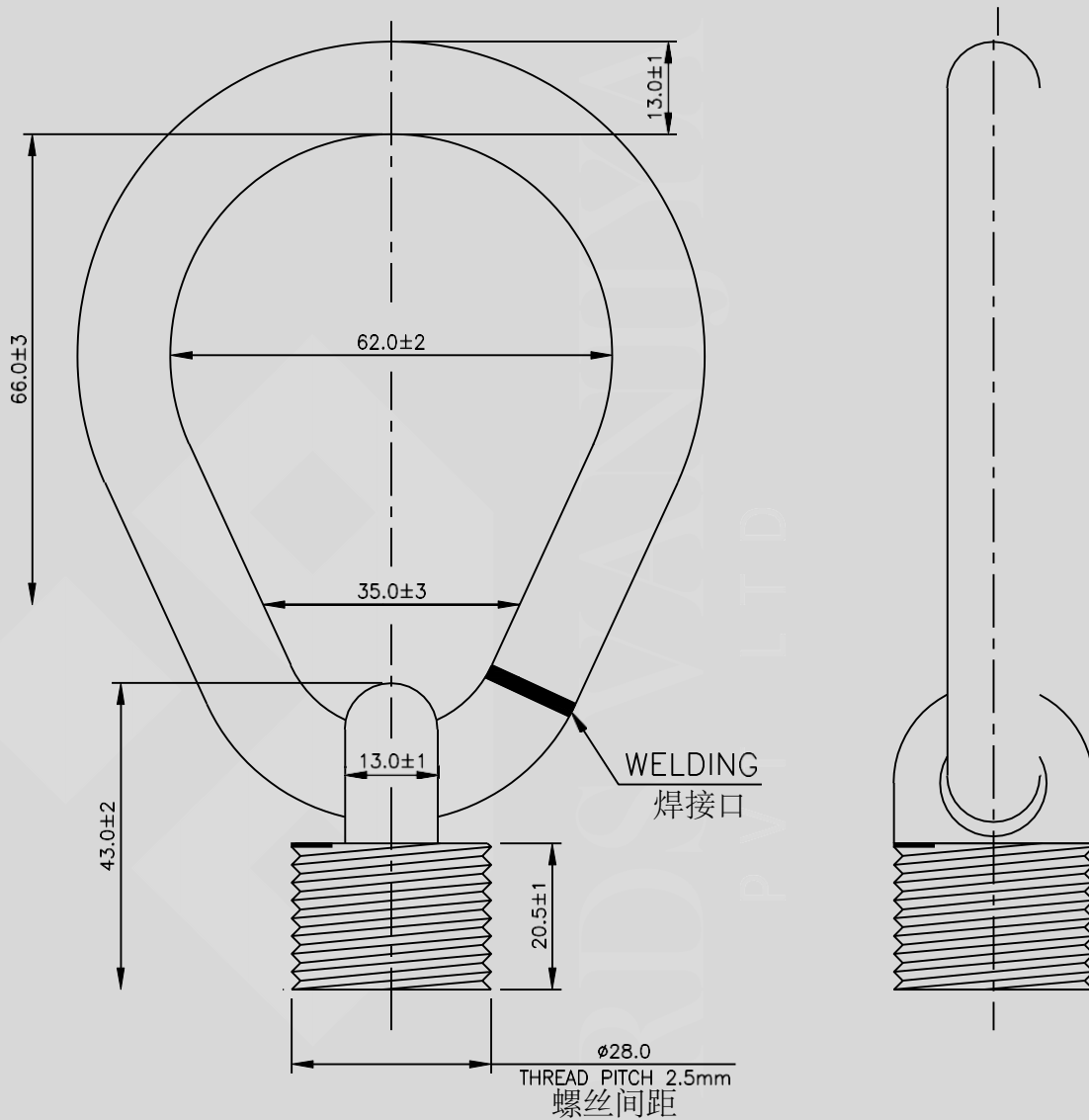

MATERIAL: STEEL GRADE EN-8 DULY HOT DIP GALVANIZED.  
 TESTING LOAD : 6 MT DEAD LOAD WITHOUT DEFORMATION  
 SCREWED IN A MATING FEMALE THREAD.

材料: EN-8级钢热镀锌

测试荷载: 插入配对螺母时, 6吨负载无变形

### KINEMATICS INC.

ALL DIMENSIONS ARE IN: mm.	TITLE:- TIE DOWN LOOP				
<u>STATUTORY NOTES</u>  RAW MATL. SPCN - FINISH MATL. SPCN - RAW MATERIAL WT - FINISH MATERIAL WT MATERIAL HARDNESS -	SCALE -	NTS	DRAWING NO.	LV-TL001	
	QTY. -	-			
	DRAWN BY			ANGLES	±
	CHKD. BY			XXDECIMAL	±
	APPROVED BY			XXXDECIMA L	±